

V5 INTERSECTIONS

FLOW CONTROL

A fully pressure compensated metering type flow control, which can be included in a V5 valve assembly. The regulated flow is supplied via the pressure gallery to 'down stream' sections, while 'up stream' are unaffected. A variety of controls are available to allow the flow to be pre-set or continually adjustable. A relief valve option limits the maximum pressure within the pressure gallery and a series link can be supplied to ensure full pump flow is available to the regulated sections even when up-stream sections are in use.

Description

A meter-in type flow control intersection, which regulates flow to 'down stream' sections only. Pressure compensated, it returns the excess flow to the tank gallery. This ensures consistent control and minimum heat generation. A relief valve option limits the maximum pressure in the pressure gallery, a series link will maintain pump flow to the flow controls even when up stream sections are in use.



Application

To be used in applications requiring precise speed control in addition to stop, start and reverse functions of the spool valve, such as winches and industrial conveyors. Can also be used to control the speed of cylinders.

Features

- Pressure compensated.
- Adjustable or pre-set.
- Screw, knob or cable operated.
- Solenoid two speed option.
- Range of metering characteristics.
- 1 turn option.
- Limited max flow option.
- Fixed flow option
- Adjustable relief valve option.
- Series link option.
- Hardened and ground components for long life.

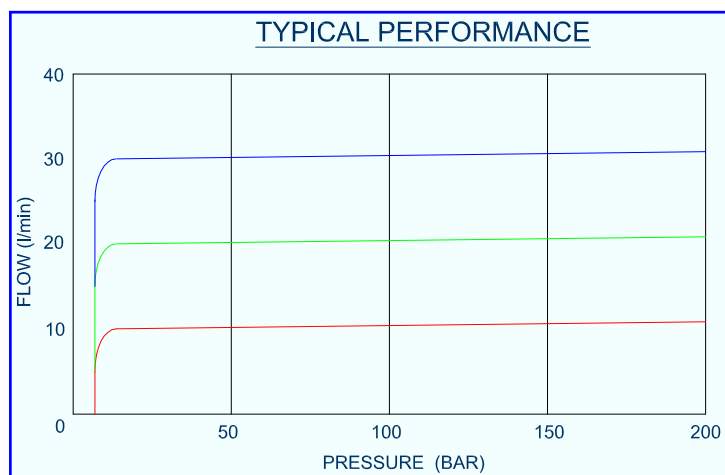

Hy-Pro

motion and control solutions

V5 INTERSECTIONS

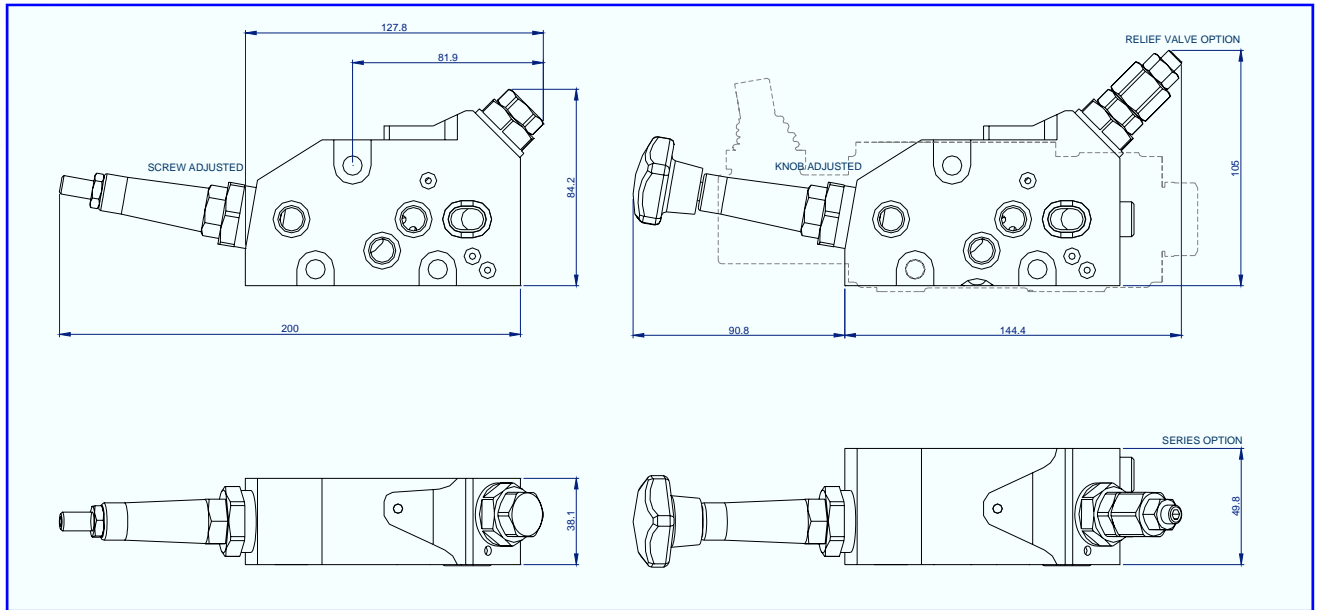

Flow Control Specification

Performance

Rated flow	60 l/min
Adjustable range	0-60 l/min
ΔP Inlet to outlet 40 l/min	0.9 bar
ΔP Inlet to service 40 l/min	6.9 bar
Maximum pressure	250 bar
Maximum back pressure	25 bar
Temperature rating minimum	-20°C
Temperature rating maximum	+60°C

Recommended Oil

Mineral based hydraulic	ISO VG37
Filtration minimum	25 micron

Materials

Body - Aluminium	BS 1490
Needle - Stainless Steel	EN58AM
External protection	Zinc chromate
	BS 1706 Zn3
	Nitrotech NQ3
	Nitrile/PTFE

Seals

Weight

FCNK

0.9 kg

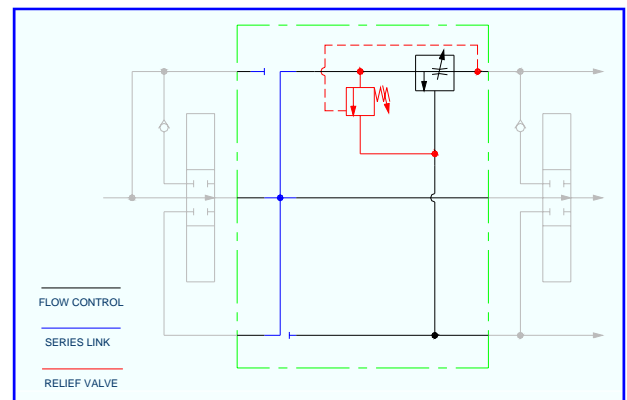

ORDER CODE

