

V5 CONTROL

DUAL AXIS LEVERS

The V5 dual axis levers operate two sections either simultaneously or individually, allowing the operator to have total control of two sections using 360 degrees of movement.

The H+ version controls section one in the north and south planes and section two in the east and west . Combinations of movement are achieved between these points.

The HX version controls both sections in the north, south, east and west planes and individual sections between these points.



Description

A mounting plate fastened to both sections provides a pivot point for the lever assembly. A yoke is then attached to each spool via ball joints, the 360 degrees of rotation generated is thus converted into reciprocating action for each spool.

Application

Industry standard for back hoe applications. Used extensively in the construction and mining industry for controlling boom movement. This type of lever is also used to control lorry mounted cranes.

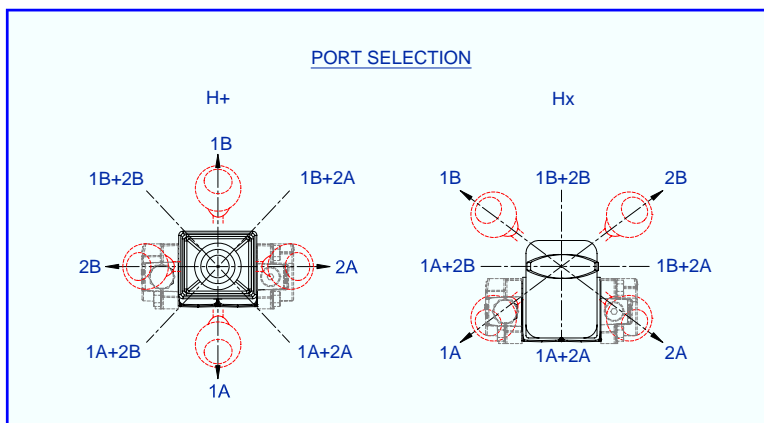

Features

- Smooth operation
- Robust construction
- Precision ball-joints.
- Steel parts.
- Protective gaiter.

V5 CONTROL

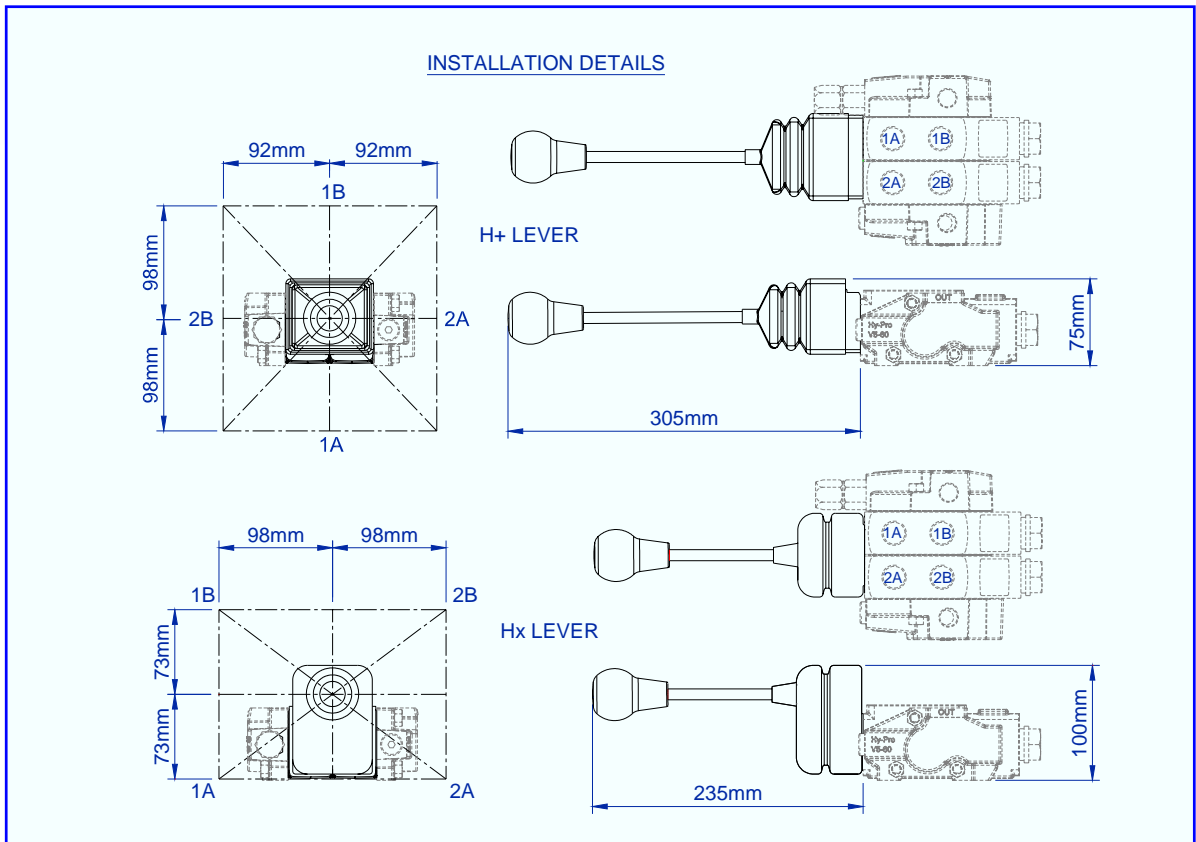

Multi Axis Lever Specification

Performance

Minimum operating Force-	
One spool	2.5 kg
Two spool	5.0 kg

Material & protection

Housing:	Aluminium BS 1490
Yoke:	Steel Nitrotech NQ3
Steel parts:	Zinc chromate BS 1706 Zn3

Weights

H+	0.53 kg
Hx	0.31 kg

ORDER CODE

