

V5 INTERSECTIONS

SOLENOID UNLOADER INTERSECTION

Designed to rapidly unload the pressure gallery to tank when power to the coil is interrupted. Can be used in both manual and solenoid operated valve assemblies as an emergency stop to override the other controls of the valve bank.

This intersection complements the range of options available for the V5 and makes it one of the most versatile valves in the Hy-Pro range.

Description

The intersection houses a normally open bypass cartridge valve which rapidly unloads the pressure gallery to tank when the solenoid coil is de-energized. When the coil is energized the bypass valve closes and the pressure is restored to the valve bank. The optional manual override can restore hydraulic operation in the event of electrical failure. A further option is the incorporation of an adjustable piloted relief valve.



Application

Required in recovery vehicle applications where winching controls must have a second control to stop the winch. Can also be used as an interlock system to prevent operation when the electrical circuit is broken.

Features

- 12Vdc or 24Vdc
- Optional manual override.
- Optional relief valve.
- N/O or N/C cartridge options
- Hardened and ground components for long life

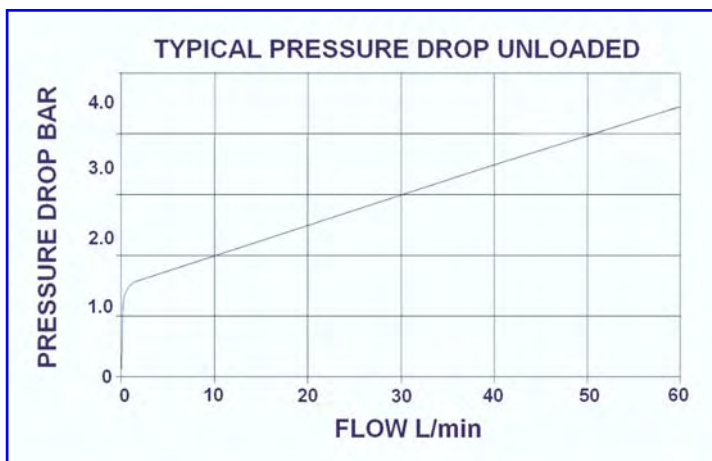

V5 INTERSECTIONS

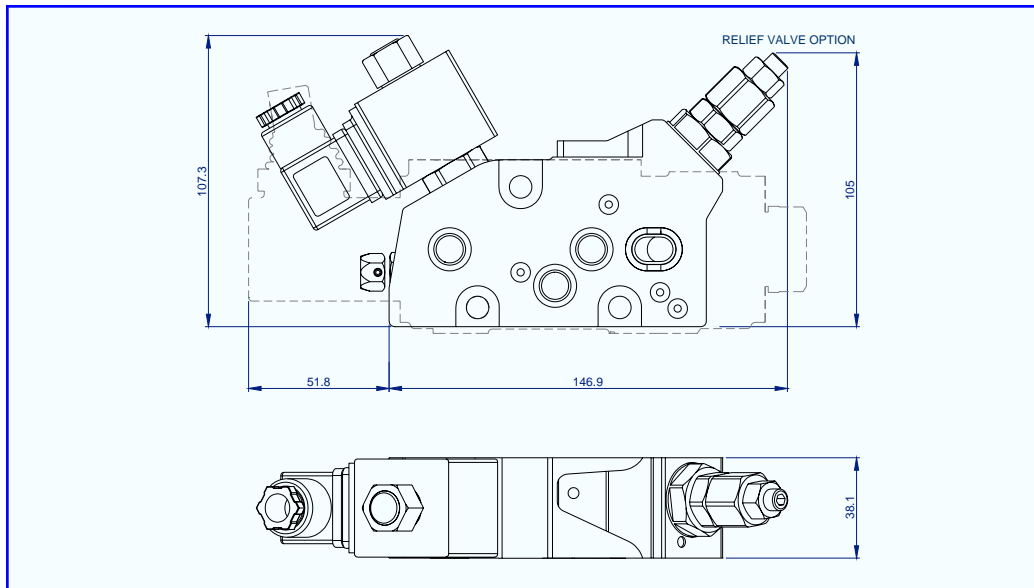

Solenoid Unloader Section Specification

Performance

Related flow	60 l/min
ΔP inlet to outlet at 60 l/min	0.9 bar
Maximum pressure	210 bar
Maximum back pressure	25 bar
Temperature rating: minimum	-20°C
Temperature rating: maximum	+65°C

Electrical

Coil voltage nominal	12V or 24V
Coil power	24W
Protection	IP65
Connection	DIN 43650

Recommended Oil

Mineral based hydraulic	ISO VG37
Filtration minimum	25 micron

Material

Body aluminium	BS 1490
External protection	Zinc chromate BS 1706 Zn3 Nitrotech NQ3

Seals Nitrile & PTFE

Weight 1.7kg

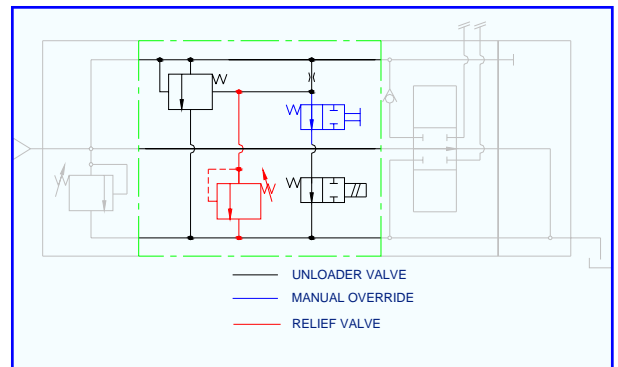

ORDER CODE

