

RELEASED DRAWING

PROVISIONAL - DRAWING FOR REVIEW ONLY NOT FOR MANUFACTURING PURPOSES
 PROTOTYPE - DRAWING FOR SMALL PROTOTYPE BATCHES
 RELEASED - DRAWING FOR PRODUCTION BATCHES

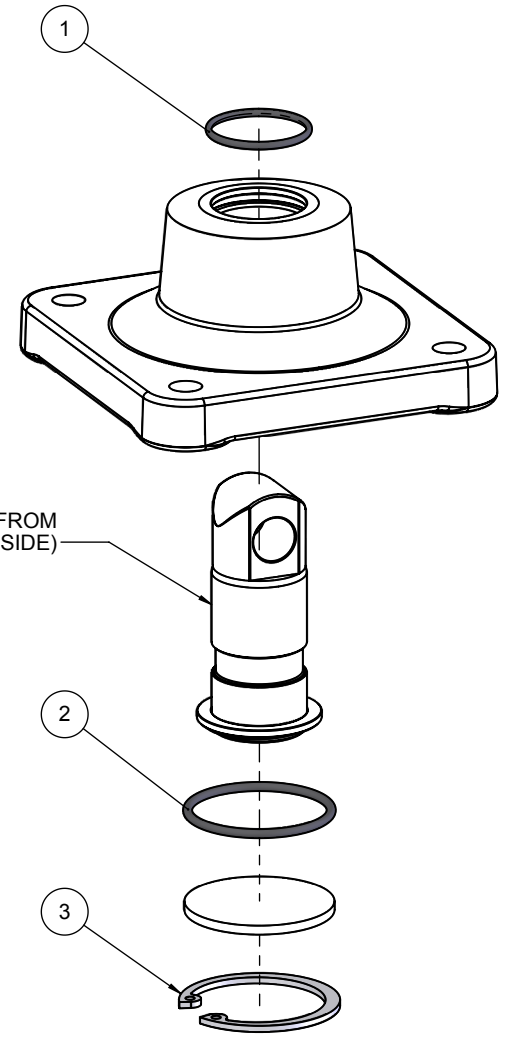
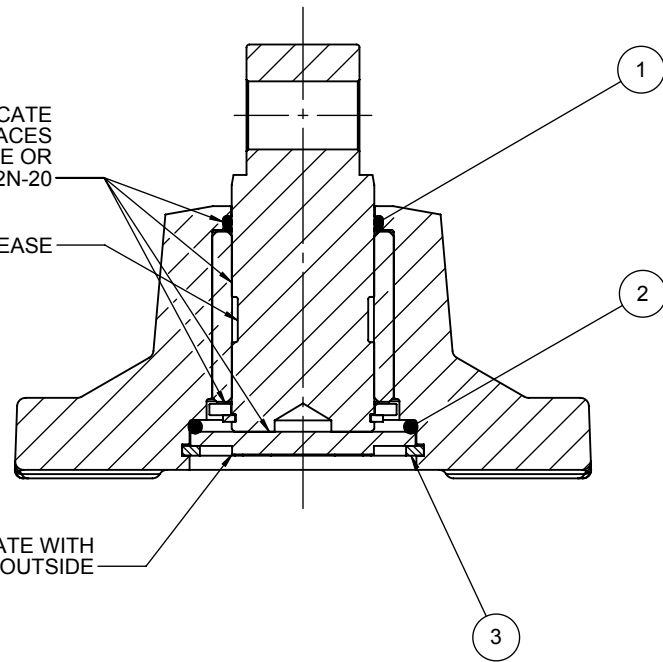

NOTES

- 1) ONLY PARTS IDENTIFIED IN BALLOONS / BOM ARE INCLUDED WITH THE KIT
- 2) KIT SHALL INCLUDE A COPY OF THE SERVICING INSTRUCTIONS:
 "K:\11 Product Documentation & Labels\Manuals & Enclosures\Customer Documentation\Marine Service Instructions.pdf"

ITEM NO.	DRG NO	PART NO	DESCRIPTION	STOCKCODE	R4075-sk
1		200-022-4490	O RING	V02640	1
2		202-672-4490	O RING	000739	1
3	B5012	B5012.40S	40 mm INTERNAL CIRCLIP TO DIN 472 (STAINLESS STEEL)	002379	1

Hy-Pro motion and control solutions © 2013 DOCUMENT: hypro.slddrw	TOLERANCES UNLESS OTHERWISE STATED DECIMAL None +/- 1 mm DECIMAL 0.0 +/- 0.25mm DECIMAL 0.00 +/- 0.10mm ANGLES +/- 0.5° REFER BS308 PARTS 1 TO 3 ALL DIMENSIONS IN mm	MATERIAL HYPRO MANUFACTURING QUALITY STANDARDS APPLY DO NOT SCALE IF IN DOUBT ASK HYDRAULIC PROJECTS LTD. 01626 863634 www.hypro.co.uk enquiries@hypro.co.uk	TREATMENT SHEET SCALE 1:1 APPROX. SCALE WHEN PRINTED A4	DESCRIPTION MOUNTING ASSEMBLY SERVICE KIT STOCK CODE NOT STOCKED	DRG NO R4075-sk Sheet1 of 2	ISSUE 02
	MOUNTING ASSEMBLY SERVICE KIT			STOCK CODE NOT STOCKED	DRG NO R4075-sk Sheet1 of 2	ISSUE 02

