

RELEASED DRAWING

PROVISIONAL - DRAWING FOR REVIEW ONLY NOT FOR MANUFACTURING PURPOSES
 PROTOTYPE - DRAWING FOR SMALL PROTOTYPE BATCHES
 RELEASED - DRAWING FOR PRODUCTION BATCHES

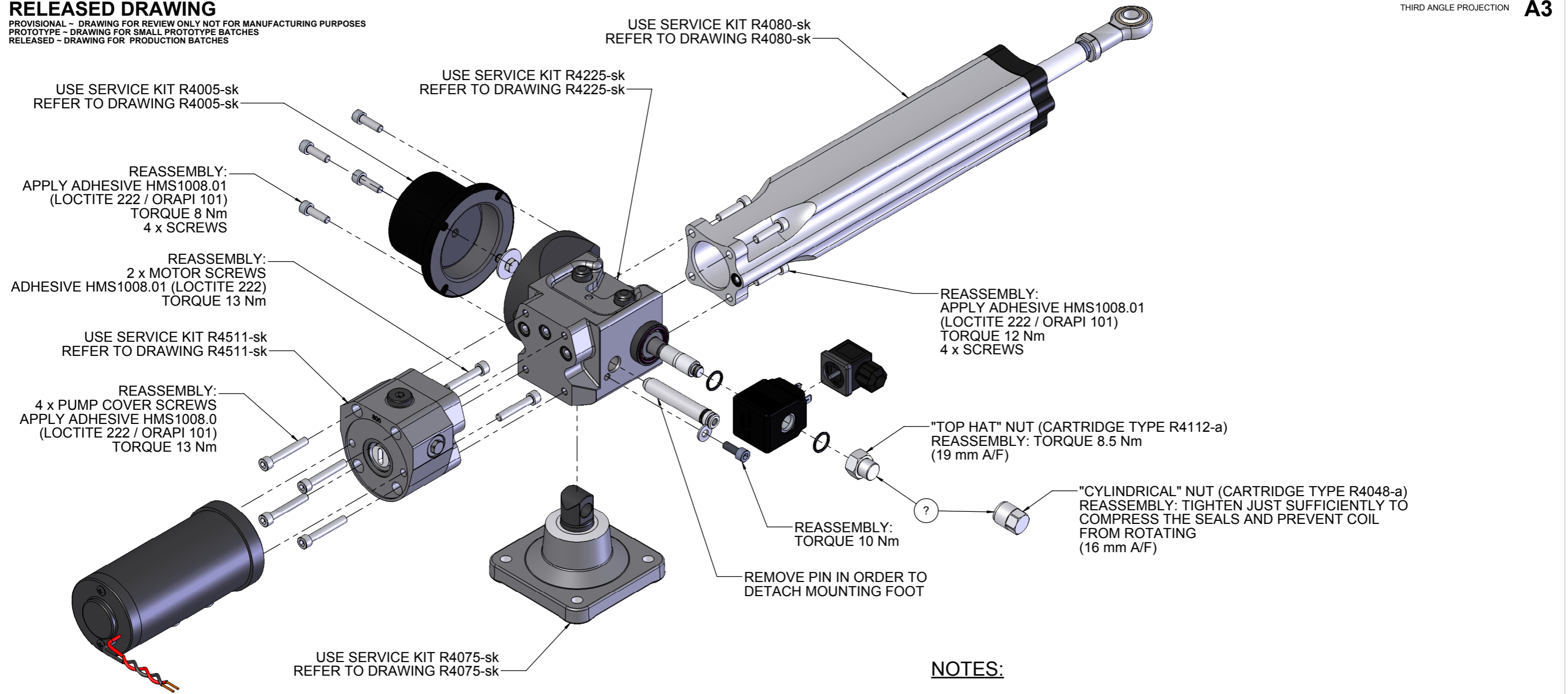

NOTES:

- 1) PRODUCT SERVICE KIT COMPRISES SUB-KITS LISTED IN TABLE
- 2) REFER TO SUB-KIT DRAWINGS FOR GUIDANCE, INCLUDING THE CORRECT BOLT TORQUES, LUBRICANTS AND ADHESIVES
- 3) AFTER REASSEMBLY BLEED UNIT USING KIT R4051: SEE OWNERS HAND BOOK FOR INSTRUCTIONS
- 4) ASTERISK (*) IN PART No. FIELD MEANS PART No. IS SAME AS DRAWING No.

ITEM NO.	DRG NO	PART NO	DESCRIPTION	STOCKCODE	QTY
1	R4075-sk	*	MOUNTING ASSEMBLY SERVICE KIT	NOT STOCKED	1
2	R4225-sk	*	ML+40 MANIFOLD SERVICE KIT	NOT STOCKED	1
3	R4511-sk	*	PR+ PUMP SERVICE KIT	NOT STOCKED	1
4	R4080-sk	*	MC+/ML+40 CYLINDER SUB ASSEMBLY SERVICE KIT	NOT STOCKED	1
5	R4005-sk	*	ML+40 RESERVOIR SERVICE KIT	NOT STOCKED	1

