

Hy-ProDrive

Marine Steering Technology
By Hydraulic Projects Ltd.



PR+

Reversing Marine Autopilot Hydraulic Pump Installation and Service Instructions

Serial Number

Please record your pumps serial number here



This precision engineered pump was designed and manufactured in the United Kingdom.

Please keep this manual in a safe place

The information in this manual was, to the best of our knowledge, correct when it went to press and Hydraulic Projects Ltd cannot be liable for any inaccuracies or omissions. There may also be differences between the specifications in the manual and the product as a result of ongoing development for which we accept no liability.

Page 4	•	Important Safety Information
5	•	Description
	•	Pump Size
6	•	Technical Data
7	•	Dimensions
8	•	Pump Selection
9	•	Location
	•	Orientation
10	•	Hydraulic Connections
11	•	Hydraulic Fluid
	•	Commissioning
12	•	Typical Arrangements
14	•	Maintenance
15	•	Motor Kits
	•	Fault Finding
16	•	Relief Valves Option
18	•	Environmental
	•	Contact details
19	•	Notes
20	•	About Hydraulic Projects Ltd.

IMPORTANT SAFETY INFORMATION

Failure to install and maintain this equipment in accordance with the instructions contained in this Manual could result in damage or injury.

This equipment must be installed and maintained by a person who is qualified to do so. This equipment is only for use with marine auto pilots within the limitations stated in the following pages.

Auto pilot steering systems are navigational aids and the user must still maintain a permanent watch.

This equipment meets the latest EMC (Electromagnetic Compatibility) standards required for use in the marine environment.
In order to ensure conformance and to prevent interference with electronic systems the unit must be properly bonded to earth and the supply cables screened.

Caution!

Do not  flash test.

Beware of hot motor and solenoid components and the risk of entrapment from moving parts.

DESCRIPTION

"PR+" reversing type gear pumps are driven by 12 or 24 volt DC permanent magnet motors. Incorporated in the design are pilot operated check valves that prevent the pump being back driven by the manual steering system or rudder load. The motors have an IP67 rating and can be removed from the pump without allowing air into the hydraulic system or fluid to escape.

Other features include compatibility with balanced or unbalanced cylinders and they can also be used with pressurised reservoir systems

If your pump is fitted with relief valves please refer to p.16 of this manual.

PUMP SIZE

The nominal flow output off load is indicated on the data label attached to the pump.

PR+05	500 cc/m
PR+06	600 cc/m
PR+08	800 cc/m
PR+10	1250 cc/m
PR+15	1800 cc/m
PR+20	2000 cc/m
PR+25	2500 cc/m

Check the voltage shown is correct for the output of your auto pilot computer.



TECHNICAL DATA

Voltage	12 / 24 VDC			
Current	Typical amp-hour		Typical current	
	5 bar at 25% duty		Intermittent 55 bar max	
	12v	24v	12v	24v
PR+05	1.3	-	10.0	-
PR+06	0.9	-	9.0	-
PR+08	1.3	-	14.0	-
PR+10	2.2	1.0	19.0	9.0
PR+15	2.4	1.2	24.0	11.0
PR+20	2.5	1.3	25.0	12.0
PR+25	2.7	1.4	34.0	15.5
Ingress Protection	IP67			
EMC Protection	BS EN 60945:2002 (DC)			
Ignition protection	BS EN 28846:1993			
Ambient operating Temperature	-15 to +55 deg C			
Max Pressure	55 bar (intermittent operation)			
Reservoir line	2 bar Max			
Ports	G1/4 (BSPP) Parallel			
	A = ram port			
	B = ram port			
	R = reservoir port			
Rotation	Red lead to - positive Pressure to A port			
	Black lead to positive - Pressure to B port			
Hoses	Suitable for working pressure 55 bar.			
	Minimum burst pressure 100 bar.			
Fluid	ISO VG10 to VG40 Hydraulic mineral fluid meeting ISO 6743-4 HV			
	The following commercial fluids are suitable.			
	Fuchs Renolin B15 HV1			
	Seastar HA5430			

DIMENSIONS

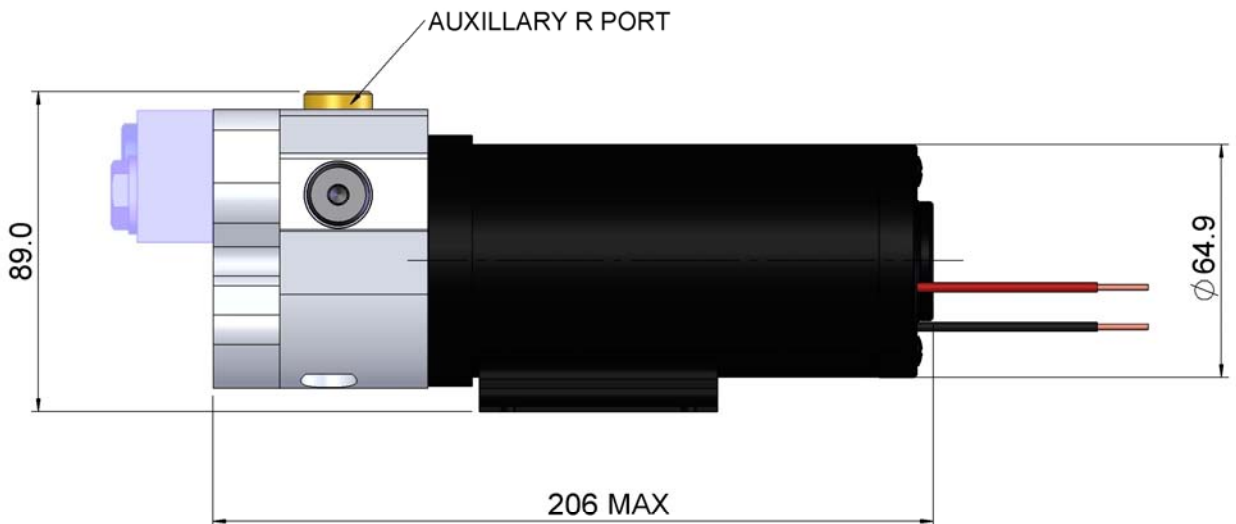
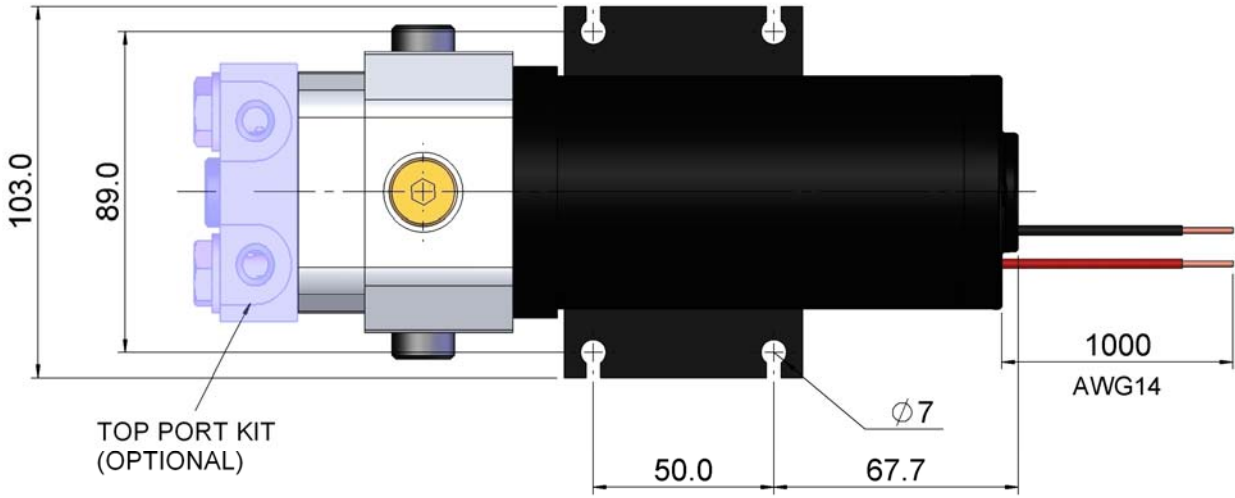

The optional top port adaptor kit is available from your dealer.
Hy-ProDrive Part no. R4516-a.

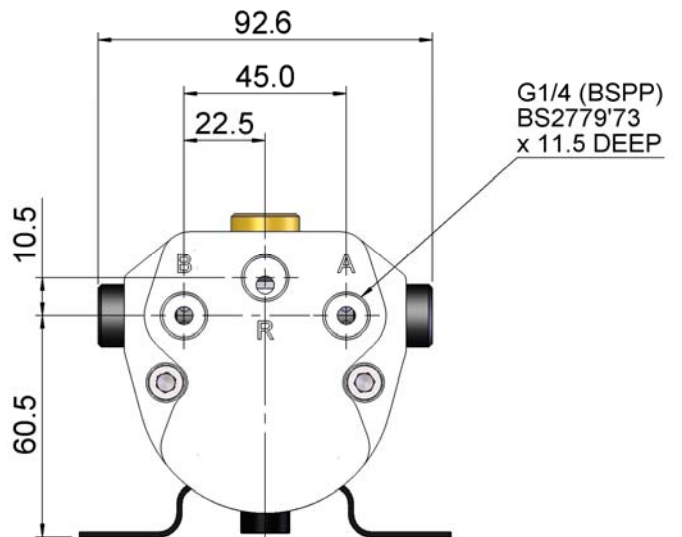

PUMP SELECTION

It is important to select the correct size PR+ pump as it directly influences the steering performance and power consumption.

The type of vessel to be steered must be considered. The hard-over time may need to be faster on lightweight planing craft and modern yachts or slower on displacement power boats or long keel yachts.

If the pump is too large, the autopilot may become over active and use more power. If it is too small the autopilot may struggle to maintain a good course.

The table below shows the volume of cylinder that each of the PR+ pumps is suited to. These selections give a nominal hard-over* time of 10-15 seconds.

In all cases refer to the information specified by your autopilot manufacturer.

Cylinder Volume (cc)	PR+
50 - 125	PR+05
100 - 150	PR+06
150 - 175	PR+08
175 - 250	PR+10
250 - 350	PR+15
350 - 450	PR+20
450 - 550	PR+25

*The hard-over time is the number of seconds that the pump takes to drive the rudder from the port to starboard stops with no flow of water over the rudder.

LOCATION

The PR+ pump is designed for “Under Deck” installations only. When considering where to mount the pump the following points should be taken into account.

- a) Keep hose and cable runs short.
- b) Mount away from sources of heat.
- c) Install the pump above areas liable to flooding.
- d) Use a solid surface to prevent noise transmission and amplification.
- e) Keep away from excessive vibration and fumes.
- f) Do not mount in confined areas containing flammable materials.
- g) The PR+ pumps can be mounted in any orientation, but the reservoir line should rise continuously.

ORIENTATION

The PR+ pumps can be mounted in any orientation. If mounting vertically then motor-up is preferable. In all cases select the R port which best allows the hose to rise continuously to the helm pump or external reservoir.

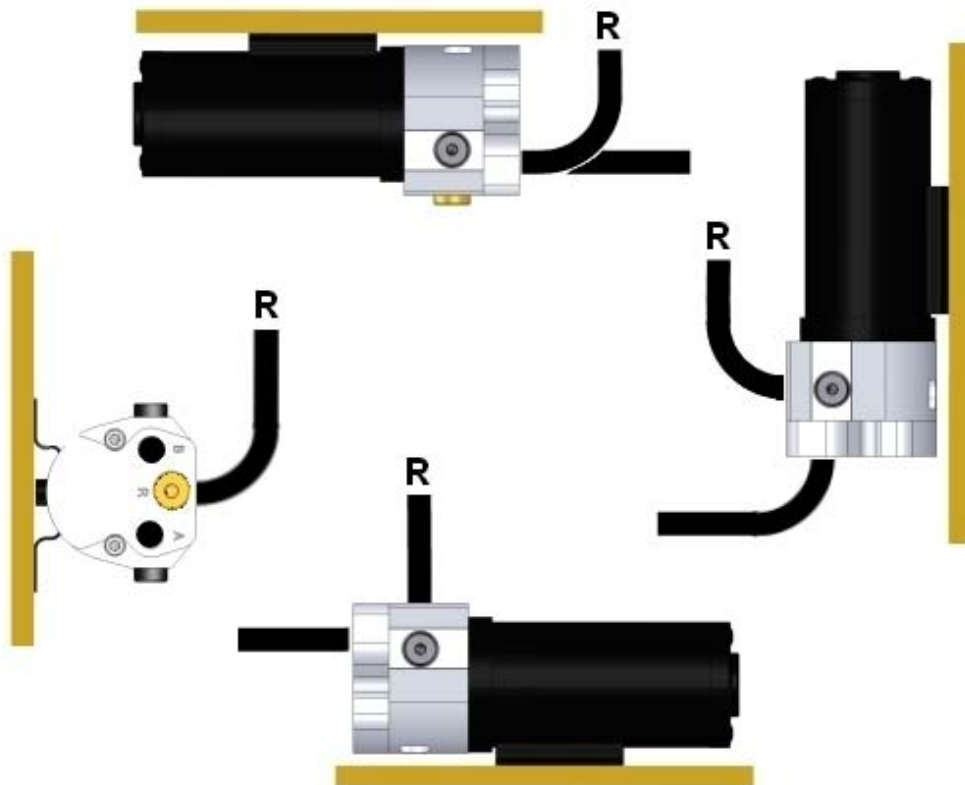

HYDRAULIC CONNECTIONS

The 'A' and 'B' and 'R' ports are G1/4(BSPP) parallel threaded.
Use only bonded rubber/metal washers to seal the fittings.
Do not use tapered adapters, sealing compound or P.T.F.E tape.



The ports marked 'A' and 'B' are the service line connections to the ram. The hydraulic hoses and connections must be of a suitable pressure rating. Refer Technical data.

The port marked 'R' is the reservoir or balance line and must be connected. Do not plug this port – damage and steering failure could result. It must be connected, through a continuous rise to the helm pump lowest connection or other external reservoir.

If used with pressurised reservoir type systems the reservoir hose must be of a suitable pressure rating. Refer Technical data

There is an optional 'R' port on top of the pump which is accessed by removing the blanking plug.

Caution!

Ensure that  no dirt enters the system during the installation, be certain that all hoses and fittings are cleaned before connecting up.

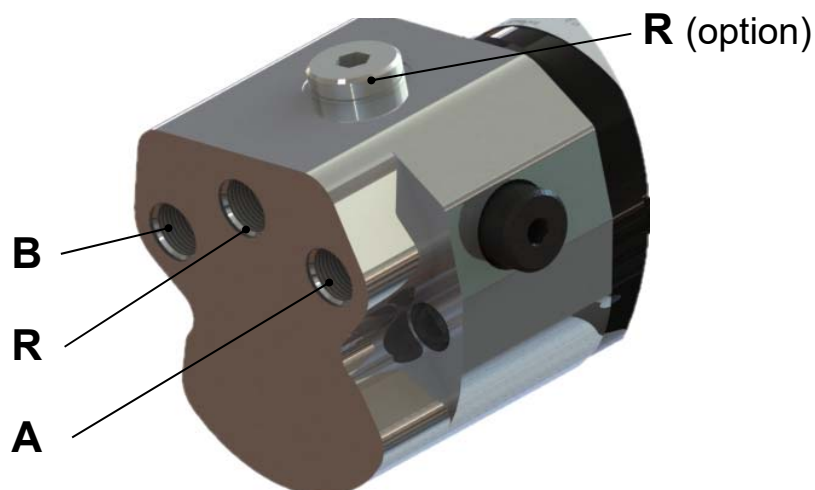

Adaptors are available in sets of 3 to convert the ports to SAE, NPTF or Metric threads.

- | | |
|---------------------------------|----------|
| A) G1/4 male to 5/8 SAE male | R2377-58 |
| B) G1/4 male to 1/4 NPTF female | R2377-N |
| C) G1/4 male to M10 female | R2377-10 |

HYDRAULIC FLUID

Caution!



Do not use "brake fluid"

Use only mineral based good quality hydraulic fluid compatible with nitrile rubber hydraulic seals.

The PR+ pump is designed to operate on a wide range of hydraulic fluids. Check the helm pump manufacturers recommendations for compatibility. Refer technical data on page 6.

COMMISSIONING

Caution!



Be aware of the danger of moving linkages and the risk of entrapment during the procedure.

The PR+ pump must not be run without fluid and is not to be used to fill or bleed the system.

Follow the helm pump manufacturers instructions to fill the hydraulic hoses so that the A, B & R hoses do not contain trapped air or air bubbles. The hose connections to the pump may need to be loosened to allow air to escape. The pump can now be run. Follow the auto pilot manufacturers set up instructions. If the pump runs but the rudder does not move, use the auto pilot to call up a course correction. This will start the pump. Manually turn the helm wheel in the same direction as the course correction. This forces fluid into the pump, displacing any residual air.

Caution!

Check all hose connections for leaks and check/maintain the fluid level in the helm  eservoir.

TYPICAL ARRANGEMENTS

Hydraulic Primary Steering

Where the primary steering is hydraulic, the PR+ pump is incorporated into the existing system. The A and B ports are teed into the hoses between the helm pump and the ram.

The R port is connected to the bottom of the helm pump (or other external) reservoir .

If your helm pump does not have internal check valves and rotates when the autopilot is engaged an in-line check valve needs to be fitted into the hoses between the helm and the pump.

Hy-ProDrive part no. R2254*.



Mechanical Primary Steering

When the primary steering is mechanical the PR+ pump can be used with either our own compact rams or with any suitable balanced or unbalanced marine steering ram.

In fig.1 an MC+ ram and reservoir are used with the PR+ pump. The solenoid controlled hydraulic clutch, used to engage and disengage the autopilot is built into the ram.

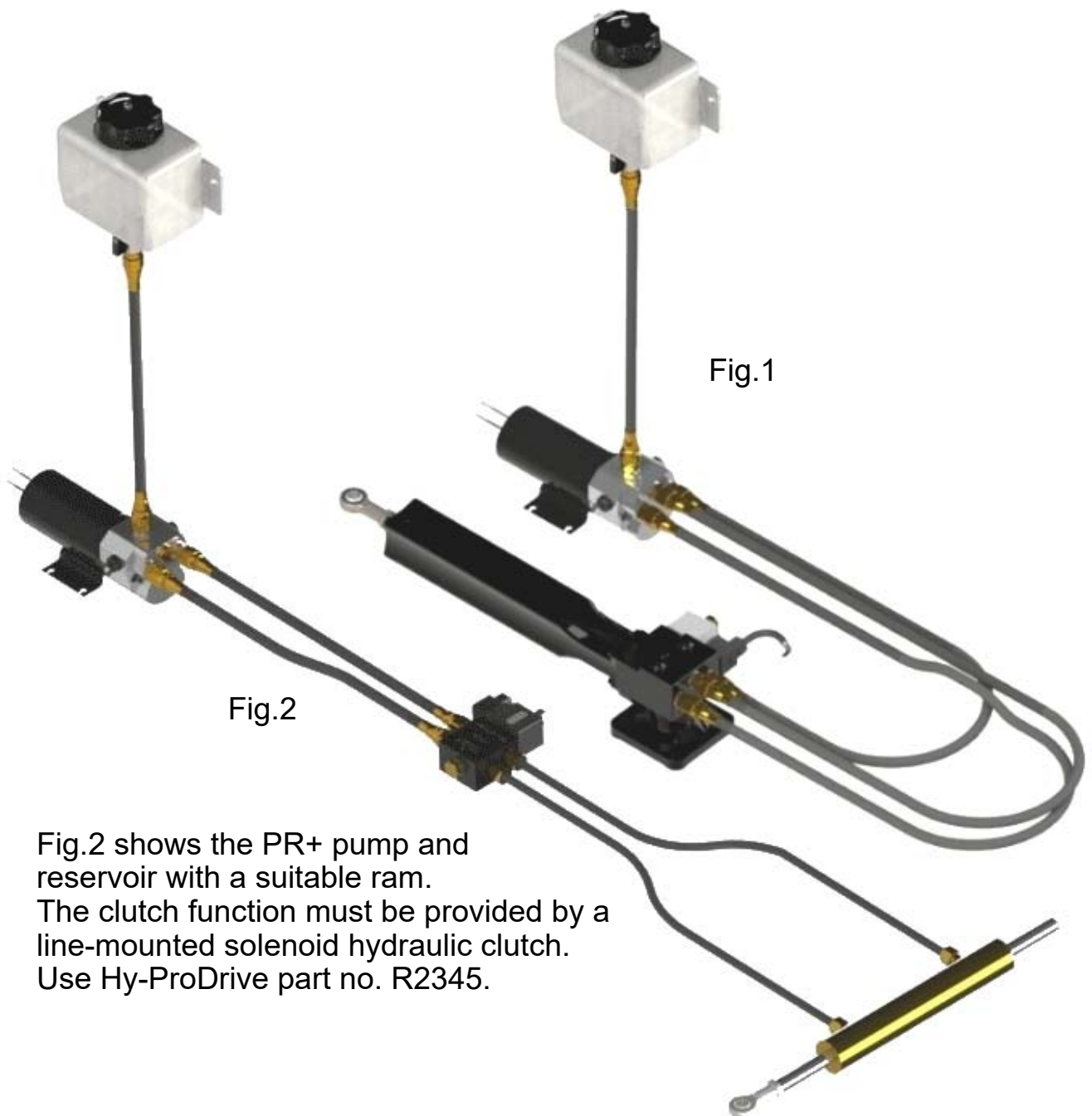

Fig.2 shows the PR+ pump and reservoir with a suitable ram. The clutch function must be provided by a line-mounted solenoid hydraulic clutch. Use Hy-ProDrive part no. R2345.

MAINTENANCE

1) Pump

With a minimum of moving parts and quality precision engineering the pump will give many years of trouble free service.

Should service replacement seals be required a kit is available.
Hy-ProDrive Part no. PR+sk.

2) Motor and coupling removal and replacement.

The long life motor is a non-serviceable item.

A new motor must be fitted in the event of motor failure, the brushes are not replaceable.

The motor can be removed (for replacement or coupling examination) from the pump head without fluid loss or air ingress into the hydraulic system.

Undo the two M6 (5mm AF Allen Key) socket head cap screws and remove the motor, coupling and water seal O ring.

If the coupling is worn or damaged please replace. Lubricate the slots with a small quantity of good quality grease.

If any hydraulic fluid is found in the coupling area the pump shaft seal must be replaced – see services kit for instructions.

Reassemble by replacing the O ring, engage the coupling between the motor and pump shafts, ensure the motor locates correctly in the pump spigot, using a low strength thread locking compound replace and tighten the two M6 socket head cap screws (13.5 Nm).

Caution!

Keep all  parts clean during dismantling and reassembly.

MOTOR KITS

Replacement motors are available under the following part numbers:

R4510-sk 12 100 = PR+10 12 PR+15 12 PR+20 12 PR+25 12

R4510-sk 24 100 = PR+10 24 PR+15 24 PR+20 24 PR+25 24

R4510-sk 12 50 = PR+05 12 PR+08 12

R4510-sk 12 25 = PR+06 12

Each kit includes the motor, seals, coupling and fitting instructions.

FAULT FINDING

1) Motor does not run

- : check electrical connections.
- : check auto pilot output.
- : check fuse / trip rating. Refer Technical Data.

2) Motor runs, but no ram movement.

- : check for air in system.
- : check for incorrect hydraulic connections.
- : check there is sufficient fluid in the system.
- : check that the relief is set correctly if fitted.
- : check the drive coupling between pump and motor.
- : check if the pump has been dismantled and incorrectly assembled.

PR+ RV OPTION

DESCRIPTION

The relief valves limit the pressure that the pump will generate.
The valves are set via 2 independent adjusters with locking nuts.

TECHNICAL DATA

(See Page 6 for all other technical data)

Adjusters	5mm hex set screw and 13mm A/F locknut screw in (clockwise) to increase.
Relief valve min setting	15 Bar
Relief valve max setting	60 Bar

CIRCUIT

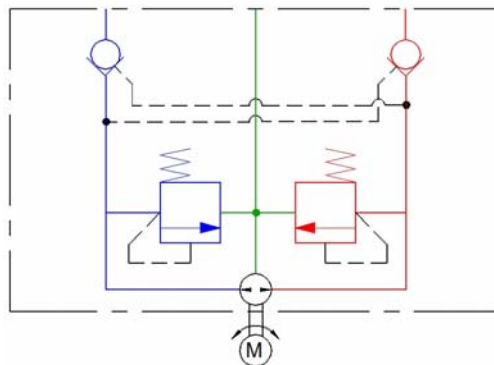

DIMENSIONS

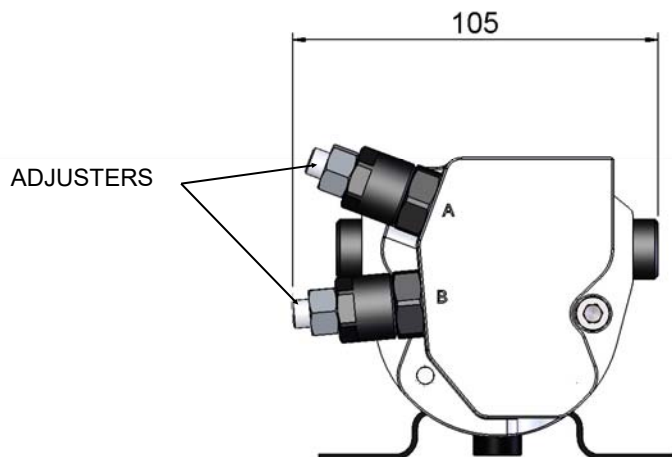
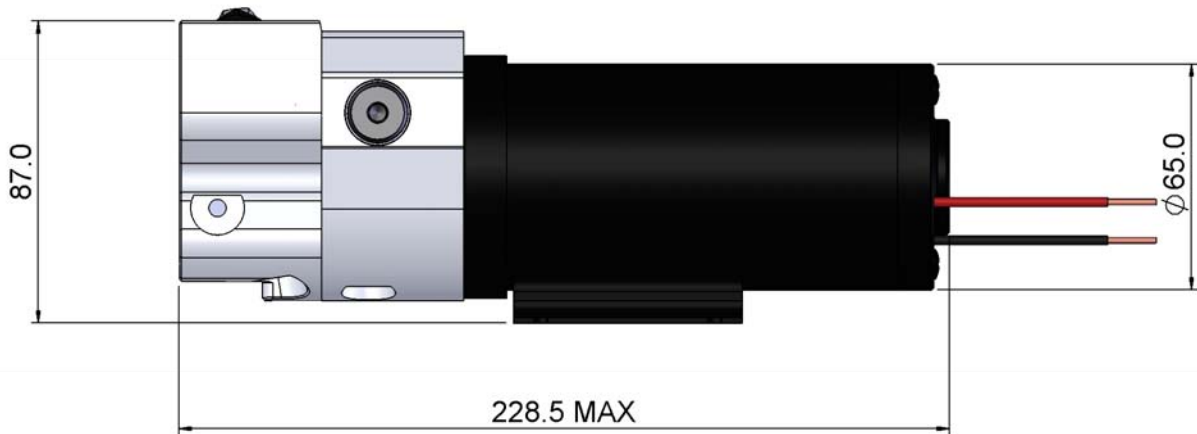
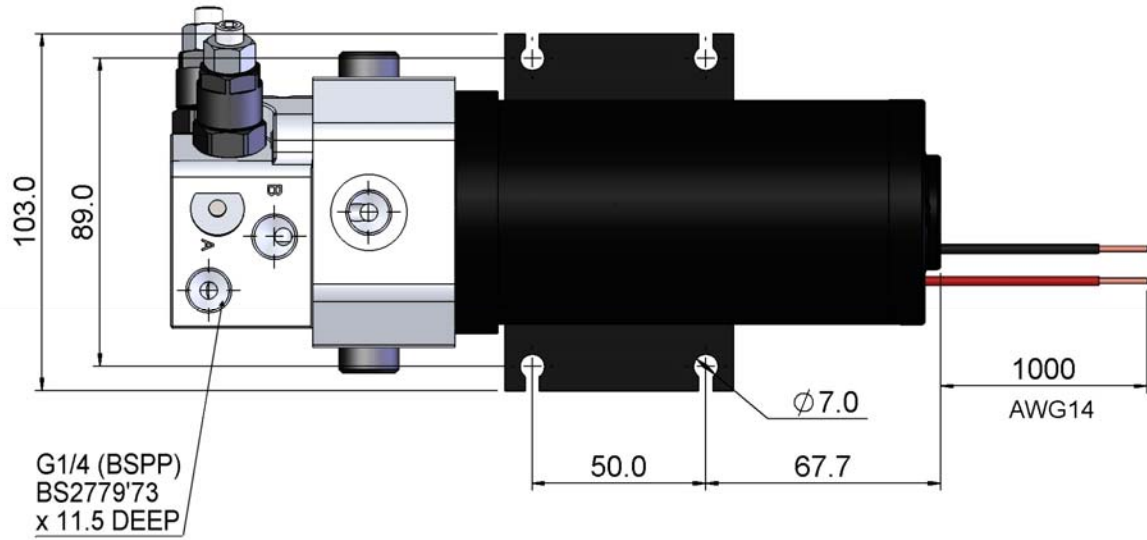

ENVIRONMENTAL

Please ensure all waste materials and fluid is disposed of properly after installation.

At end of life disposal this product should be recycled.

CONTACT DETAILS

Hydraulic Projects Limited

Dawlish Business Park
Dawlish
Devon
EX7 0NH
United Kingdom

Telephone +44 (0)1626 863634

Email sales@hypro.co.uk

Web www.hypro.co.uk



NOTES



Our in-house design and technical teams offer the expertise and support expected of an established world-class manufacturer. Our customers, ranging from the agricultural, transport, rail, fishing, construction and industrial sectors, expect named personal support, excellent quality and a rapid service with full back-up...

....we aim to deliver in full.

Call us today to discuss a bespoke solution from our extensive range or simply for competitively priced spares.

Full technical details of our entire range are available to download from our website

www.hypro.co.uk