

| ISS. DRN | DRAWN BY | DATE DRAWN   | CHECKED BY | CHANGES       |   |
|----------|----------|--------------|------------|---------------|---|
| 02       | 10637    | Barry Wynn   | 11/08/2009 | James Roberts | ITEM13 - V3083 REMOVED, ORININAL LEVER & SEAL VIEWS DELETED |
| 03       | 10647    | Barry Wynn   | 27/08/2009 | James Roberts | ITEM 5 BALLOON ADDED - INCORRECTLY DELETED AT ISSUE 02      |
| 04       | 11078B07 | Clive Morley | 19/05/2015 | Magnus Cooper | REFER DRN   |

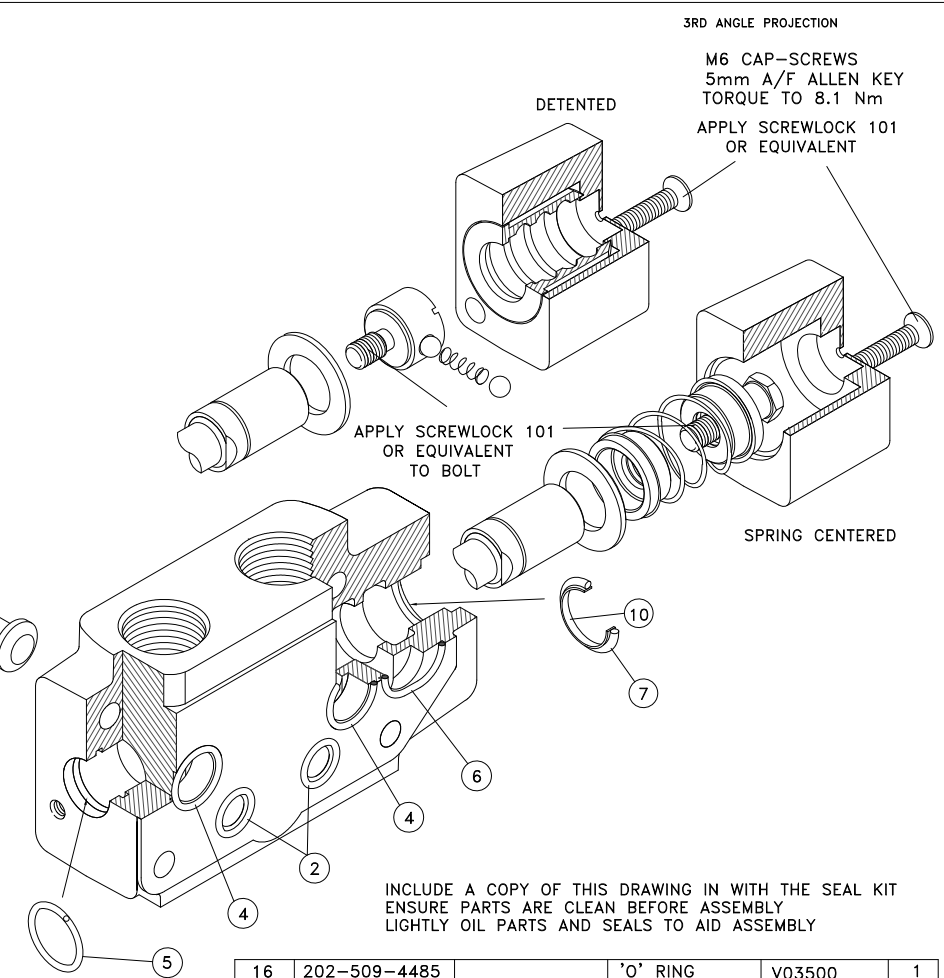
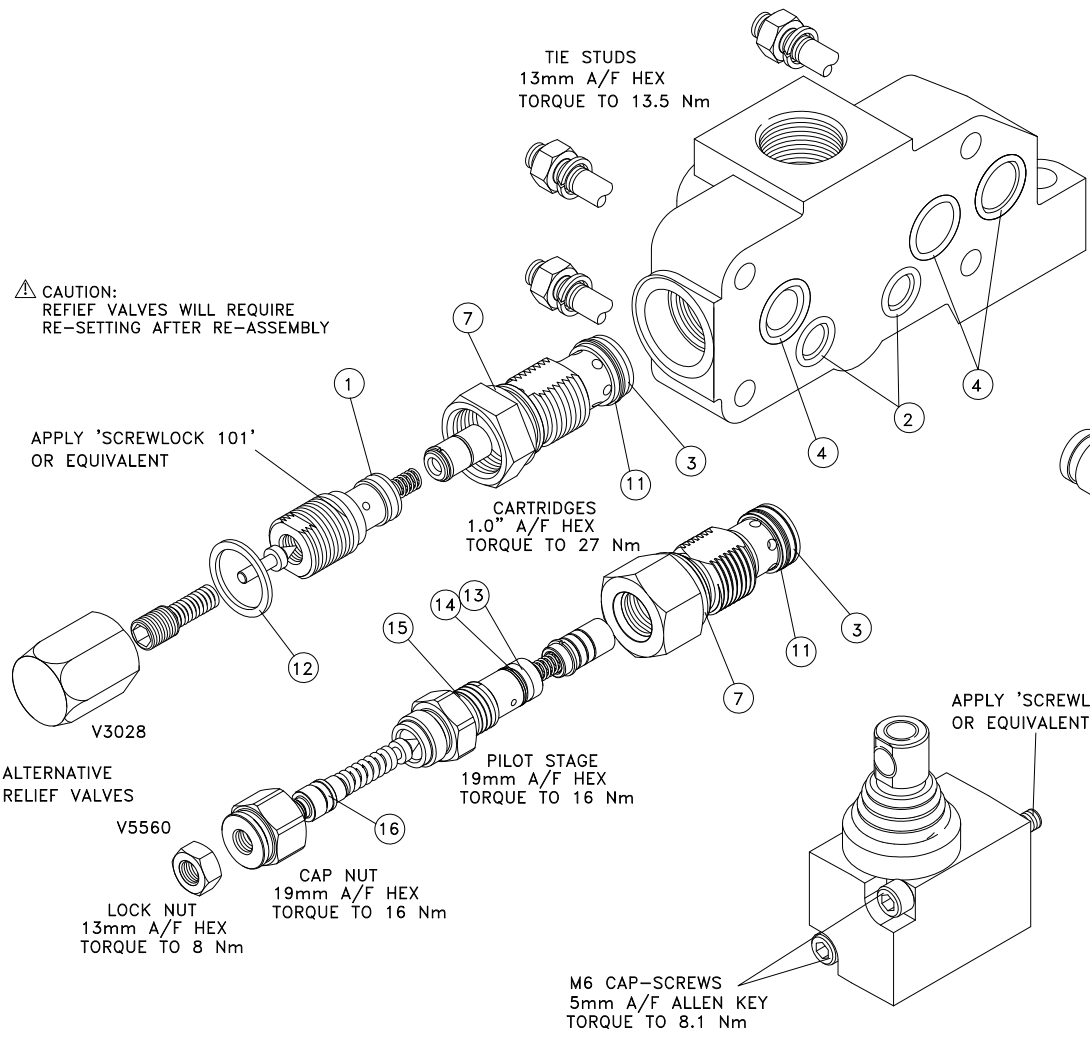

| 16   | 202-509-4485 |            | 'O' RING       | V03500     | 1   |
|------|--------------|------------|----------------|------------|-----|
| 15   | 200-906-4490 |            | 'O' RING       | V02978     | 1   |
| 14   | BS012        |            | A-E RING       | V04040     | 1   |
| 13   | 200-012-4490 |            | 'O' RING       | V02540     | 1   |
| 12   | B1001.08     | B1001      | COPPER WSHR    | V05200     | 1   |
| 11   | BS 016       |            | A-E RING       | V04080     | 1   |
| 10   | V3050        | V3050      | SLIP RING      | V04520     | 1   |
| 9    | BS0141-16    |            | A-E RING       | V04260     | 1   |
| 8    | 202-516-5590 |            | 'O' RING       | V03510     | 1   |
| 7    | 200-117-4490 |            | 'O' RING       | V02950     | 2   |
| 6    | 200-019-4490 |            | 'O' RING       | V02610     | 1   |
| 5    | 200-018-9975 |            | 'O' RING VITON | V03100     | 1   |
| 4    | 200-017-4490 |            | 'O' RING       | V02590     | 5   |
| 3    | 200-016-4490 |            | 'O' RING       | V02580     | 1   |
| 2    | 200-014-4490 |            | 'O' RING       | V02560     | 4   |
| 1    | 200-013-4490 |            | 'O' RING       | V02550     | 1   |
| ITEM | PART NUMBER  | DRG NUMBER | DESCRIPTION    | STOCK CODE | QTY |

# Hy-Pro

© 2003  
FORM 1 H:\CAD\BORDER\BORDER

**MATERIAL**  
HYPRO MANUFACTURING QUALITY  
STANDARDS APPLY  
DO NOT SCALE  
IF IN DOUBT ASK

**TREATMENT**

ORIGINAL SCALE: 1:1  
FIRST DRAWN: C.MORLEY 8/9/03  
CHECKED  
STOCK CODE: V3SK

TOLERANCE UNLESS OTHERWISE STATED  
DECIMAL .0 +/- .015"  
DECIMAL .00 +/- .010"  
DECIMAL .000 +/- .005"  
ANGLES +/- 0 deg 30'  
CONCENTRICITY .005" T.I.R. MAX

REFER BS308  
ENGINEERING DRAWING PRACTICE  
PARTS 1 TO 3

**V3-100 VALVE SECTION SEAL KIT**

PAGE 1 OF 2

ISSUE: 04

V3000-sk

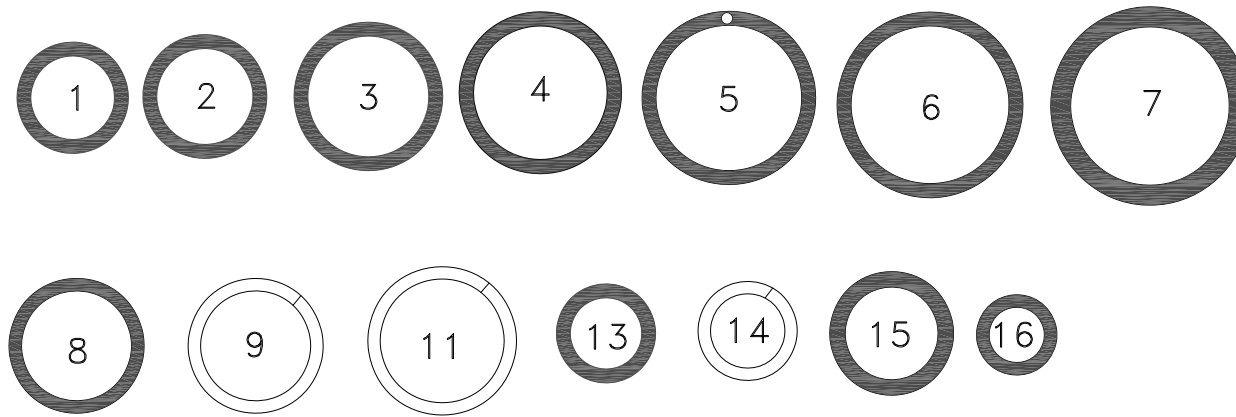

SEALS PRINTED ACTUAL SIZE FOR IDENTIFICATION

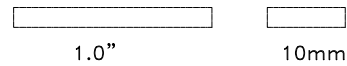

**Hy-Pro**

© 2003

FORM 1 H:\CAD\BORDER\BORDER

MATERIAL  
HYPRO MANUFACTURING QUALITY  
STANDARDS APPLY  
DO NOT SCALE  
IF IN DOUBT ASK

TREATMENT

|                       |                                   |         |                    |
|-----------------------|-----------------------------------|---------|--------------------|
| ORIGINAL SCALE<br>1:1 | FIRST DRAWN<br>C.MORLEY<br>8/9/03 | CHECKED | STOCK CODE<br>V3SK |
|-----------------------|-----------------------------------|---------|--------------------|

TOLERANCE  
UNLESS OTHERWISE STATED  
DECIMAL .0 +\ - .015"  
DECIMAL .00 +\ - .010"  
DECIMAL .000 +\ - .005"  
ANGLES +\ - 0 deg 30'  
CONCENTRICITY .005" T.I.R. MAX  
REFER BS308  
ENGINEERING DRAWING PRACTICE  
PARTS 1 TO 3

V3-100 VALVE SECTION  
SEAL KIT

PAGE 2 OF 2

V3000-sk

ISSUE  
04